

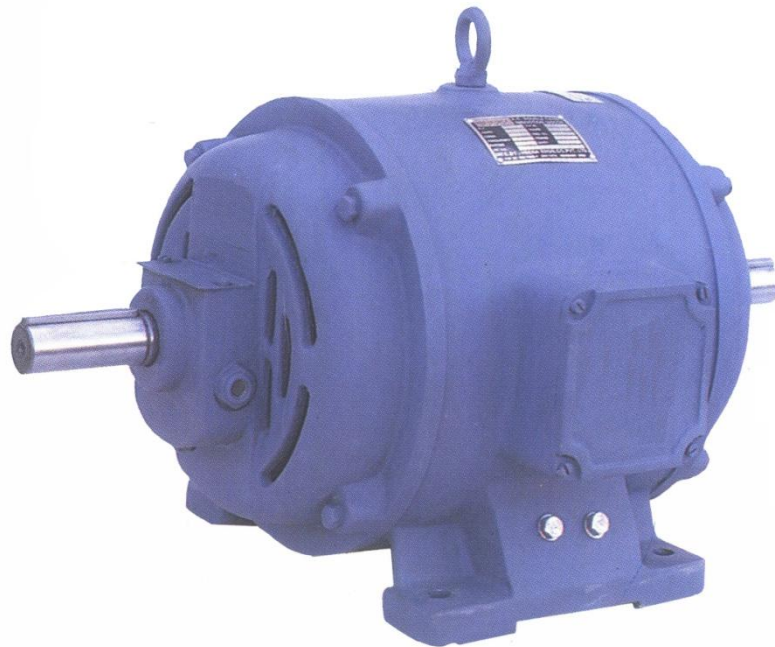

LIFT DUTY MACHINE MOTOR

High Loaded Lift Duty Machine Motor



MOTORING THE WHEELS OF SUCCESS



Lift Duty Machine –Motor:

“SONAL” Lift an upper traction unit machine is Developed from worm reduction gear units. This unit has been designed for the special purpose of this wear silence & smoothness is required.

Sleeve bearings are used in worm shaft with angular contact bearings are provided on wheel shaft for maximum load carrying capacity. Oil seals are not provided in gear box. All gears have limited backlash for lift operation. Backless adjustment facility is provided which makes machine life longer

Special care is taken for oil circulation so that ample quantity of oil reaches all sleeve bearings imparting longer life. These high quality unit offer maximum economy with minimum maintenance & require only periodic oil checking.

These motors are specially designed for lift for smooth starting & silent operation. Rotor is of Double cage copper bars & dynamically balanced Sleeve bearings are provided with self circulating oil system but without oil seals. It gives starting torque of 2 to 2.5 times the full load torque. Motor are suitable for 120 stats per hour. Oil recommended SAE-40 of Indian Oil Corporation.

PINCIPAL DIMENSIONS(M.M.):-

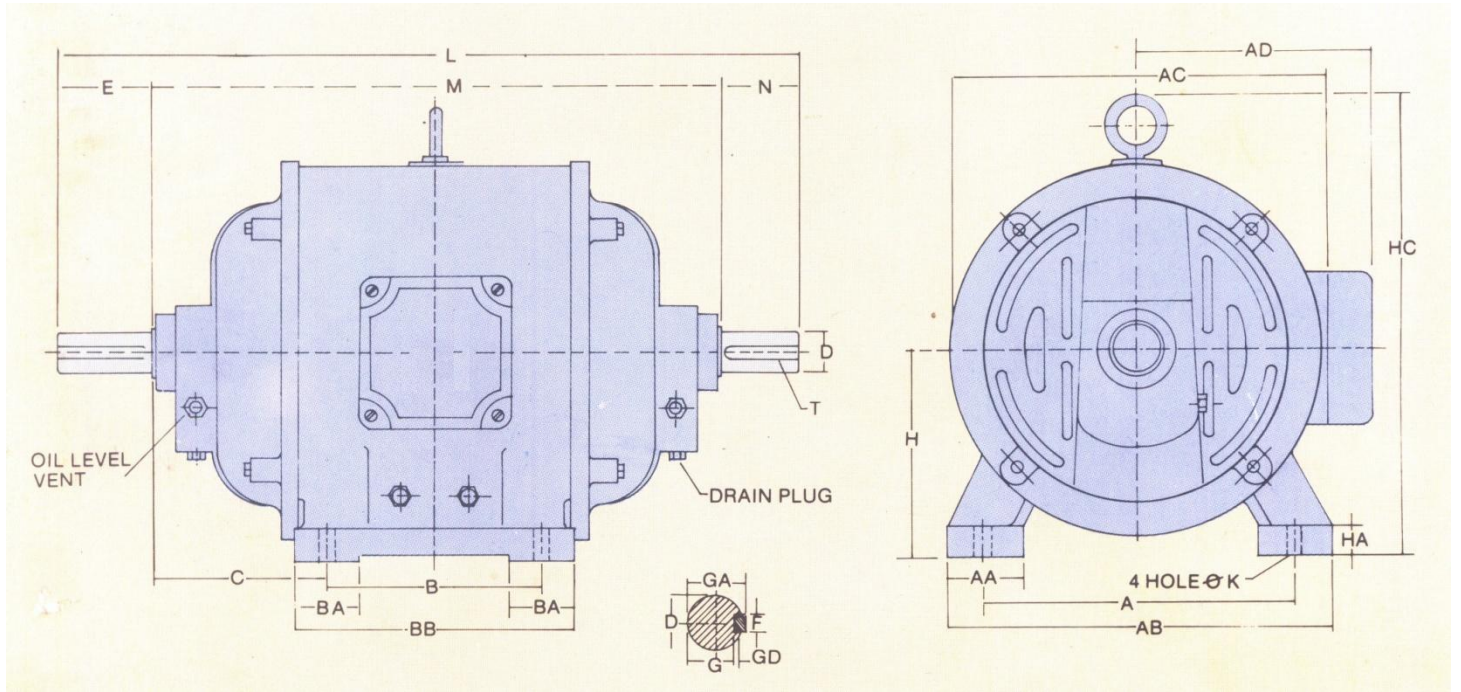

H.P.	FRAME	FOOT FIXING										SHAFT				KEY & KEY WAY				OVERALL					
		A	B	C	H	AA	AB	BA	BB	K	D	E	F	G	GA	GD	AD	AC	L	M	N	HC	HA	T	
4	132 M	245	145	140	132	50	285	50	184	12.7	31	74	7.93	27.5	34.5	3.5	176	257	564	430	60	320	21	M8	
5	160 M	250	175	135	160	55	295	55	220	15	31	74	7.93	27.5	34.5	3.5	195	285	584	450	60	360	30	M8	
7.5	160 L	250	205	135	160	55	295	55	245	15	31	74	7.93	27.5	34.5	3.5	195	285	614	480	60	360	30	M8	

Sonal Machine Tools

Admin office / works:

**30/30 Adeshwar Estate opp. Shankar Estate,
Revabhai Estate Road, C.T.M. , Amraiwadi
Ahmedabad - 380026
(Gujarat-India)**

Tel: 079-25860485, 25860290

Fax: 079-25860485

Mobile: +919898278390

Email: sonalindia@rediffmail.com

Website: sonal-motors.com

Authorised Dealer :

